

**SCHEDA TECNICA**  
COPRIWATER IN RESINA POLIESTERE

Codice articolo: **45139**

Nome articolo: **TIPO**

Azienda: **VINCENTI**

Cerniera: **UNIVERSALE CON VITE IN TESTA**

Paracolpi anteriori: **mm 08 - 2 CHIODI**

Paracolpi posteriori: **mm 10 - 2 CHIODI**

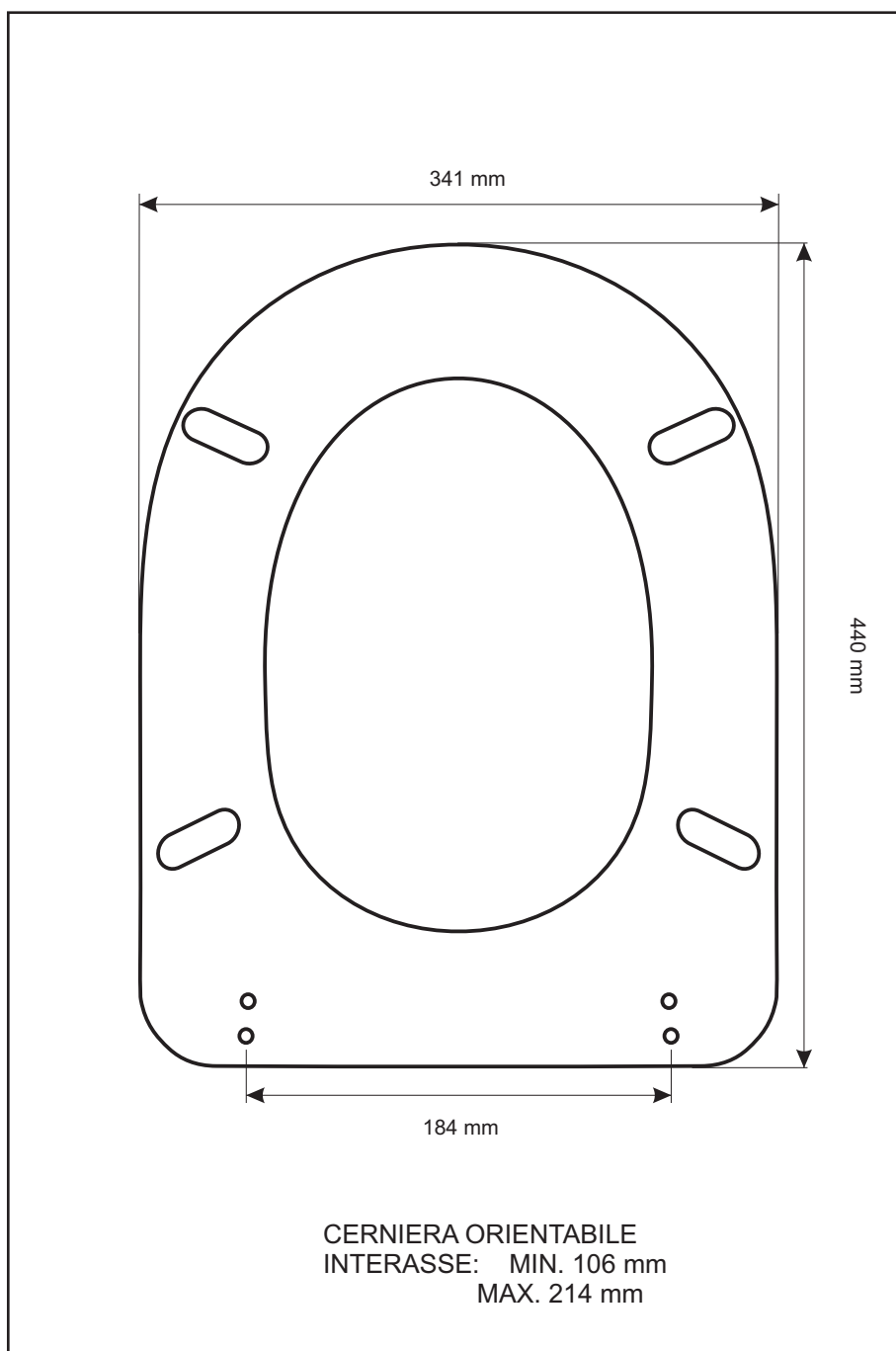

CERNIERA



PARACOLPI ANTERIORI



PARACOLPI POSTERIORI